



EVOTECH®
P E R F O R M A N C E

Yamaha MT-09

Tail Tidy

Installation Instructions



Kit Contents PRN013753

- | | |
|-----------------------------|--------------------------------|
| Ⓐ 1 x Main Bracket | Ⓜ 2 x M5 x 20 Button Head Bolt |
| Ⓑ 1 x Lower Bracket | Ⓝ 2 x O-Rings |
| Ⓒ 1 x Main Tail Tidy | Ⓞ 2 x Vinyl Caps |
| Ⓓ 1 x Upper Tail Tidy | Ⓟ 2 x Indicator Retainer |
| Ⓔ 1 x Axle Block R/H | Ⓠ 2 x Indicator Extensions |
| Ⓕ 1 x Axle Block L/H | Ⓡ 2 x M4 Nuts |
| Ⓖ 1 x Reflector Kit | Ⓢ 4 x M6 x 16 Button Head Bolt |
| Ⓗ 1 x Retro Light | Ⓣ 8 x M4 x 8 Button Head Bolt |
| Ⓘ 1 x Rear Light Connector | |
| Ⓙ 1 x Light Mount | |
| Ⓚ 2 x Indicator Mount Upper | |
| Ⓛ 2 x Indicator Mount Lower | |

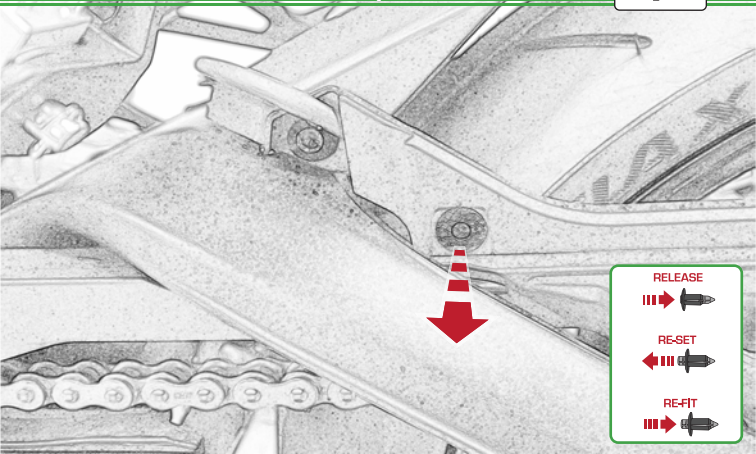

RELEASE



RE-SET



RE-FIT



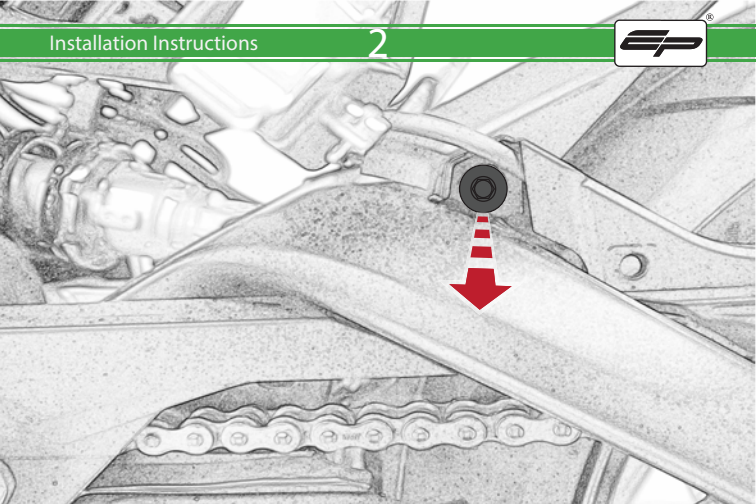

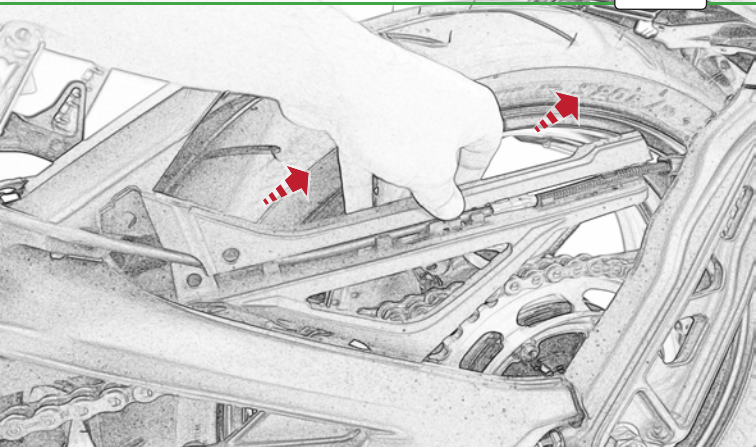

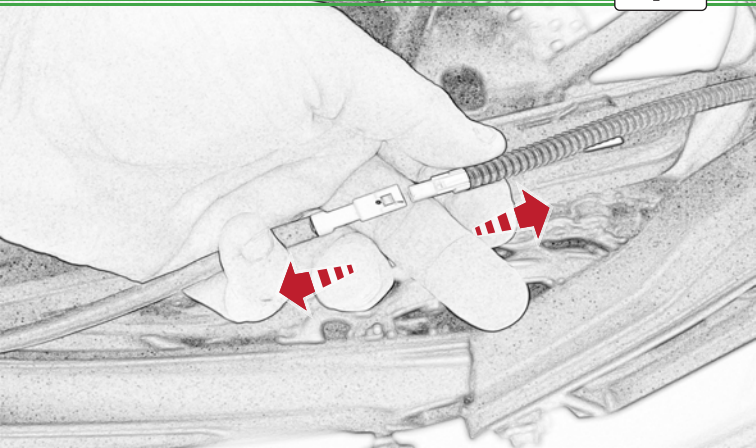



Reverse Stages

3 - 1

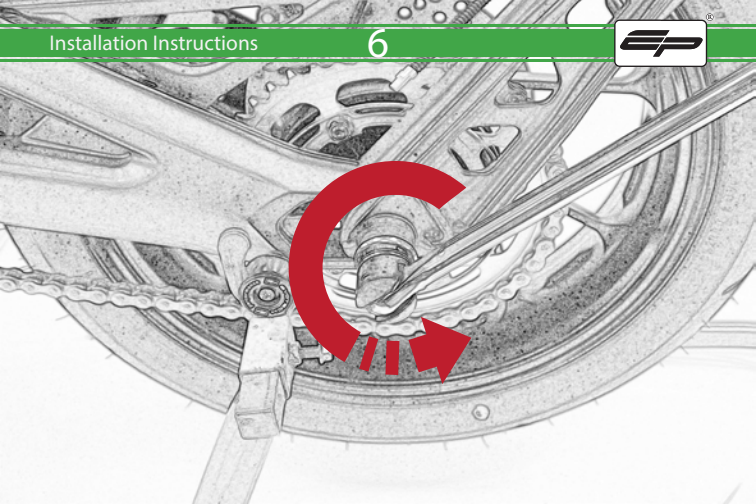

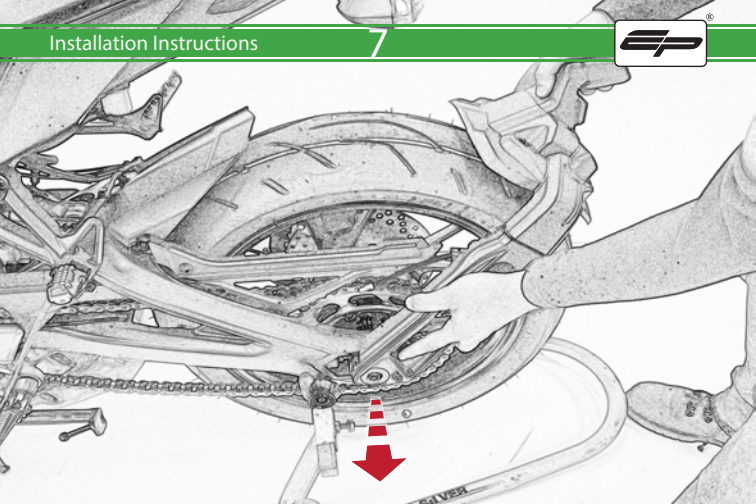

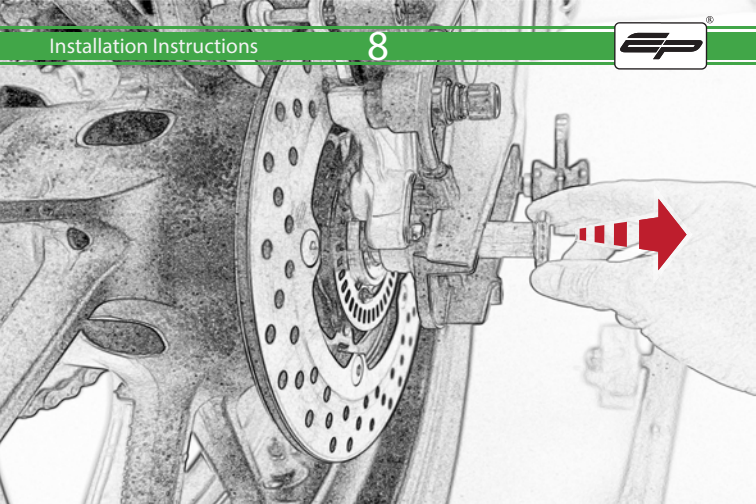

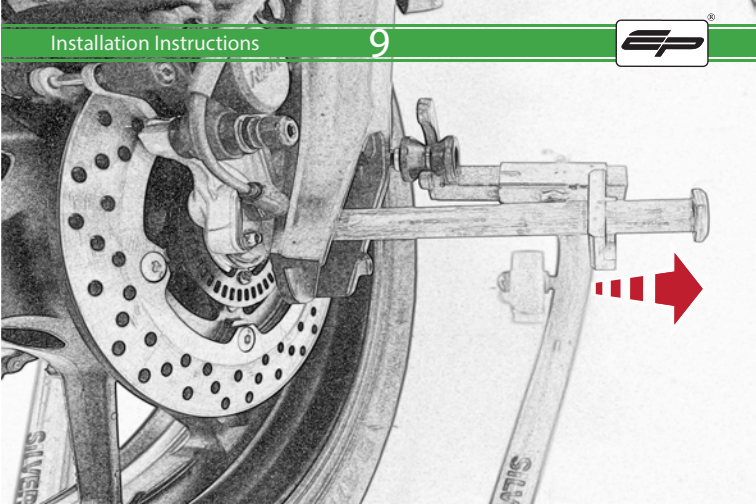

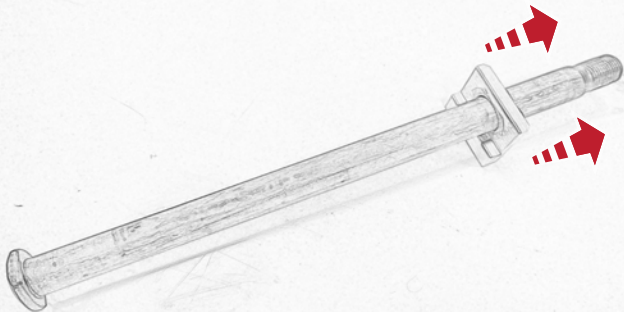

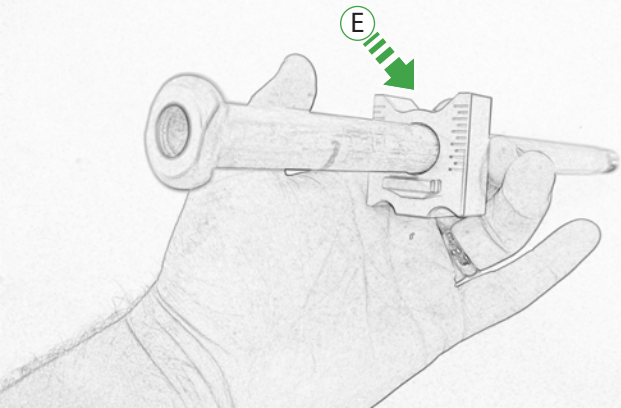

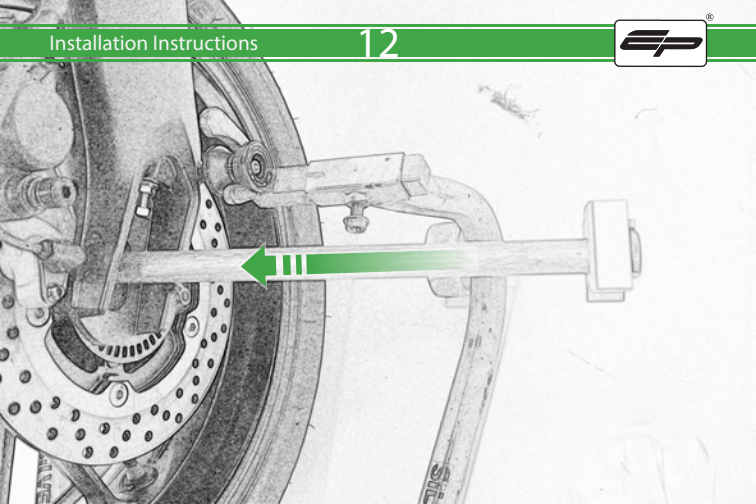

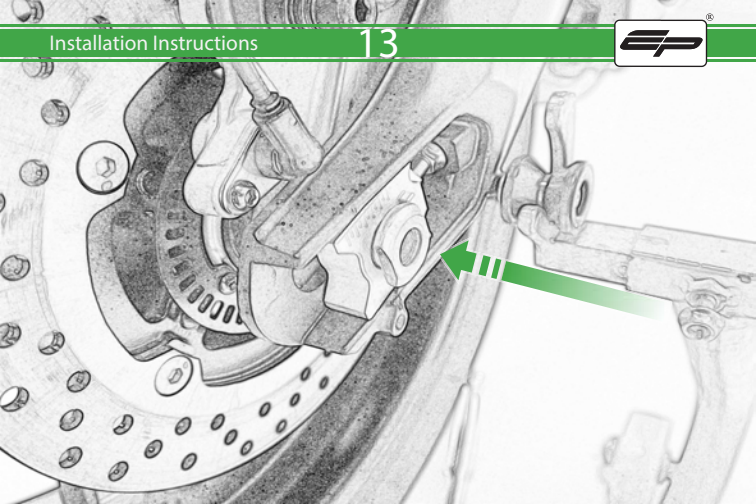

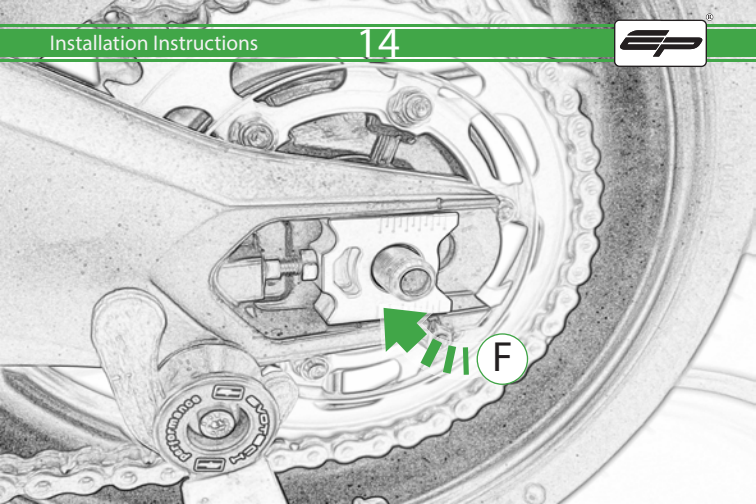

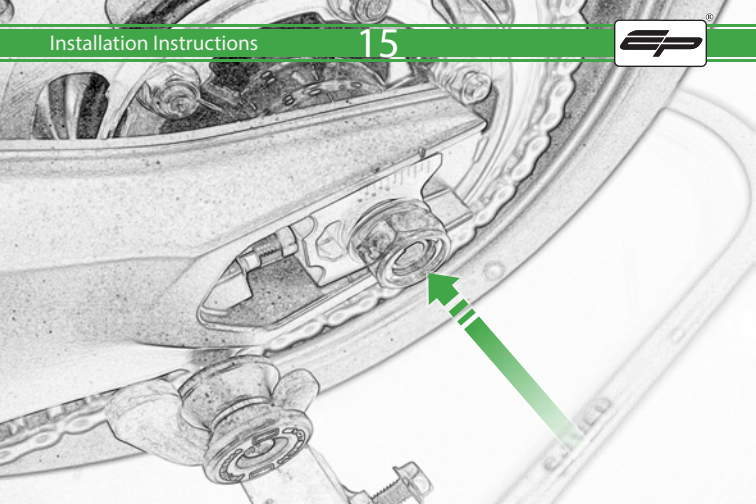



Torque 108ft lb
Torque 147N m

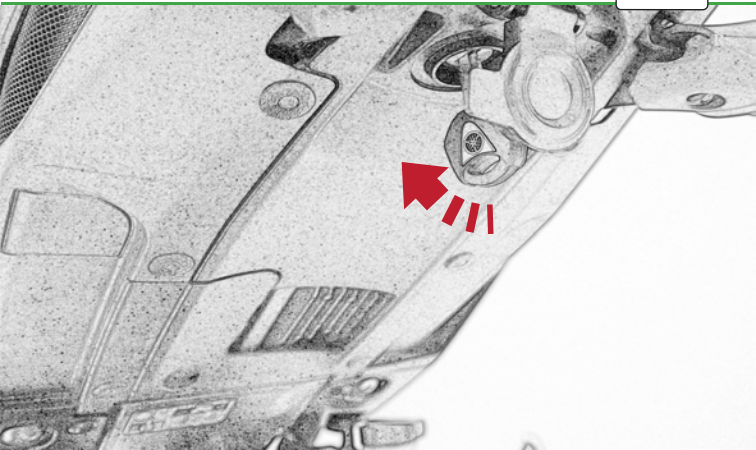

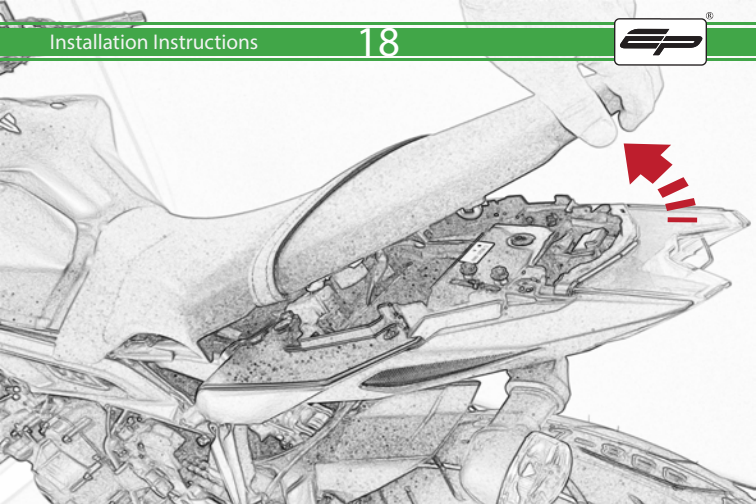

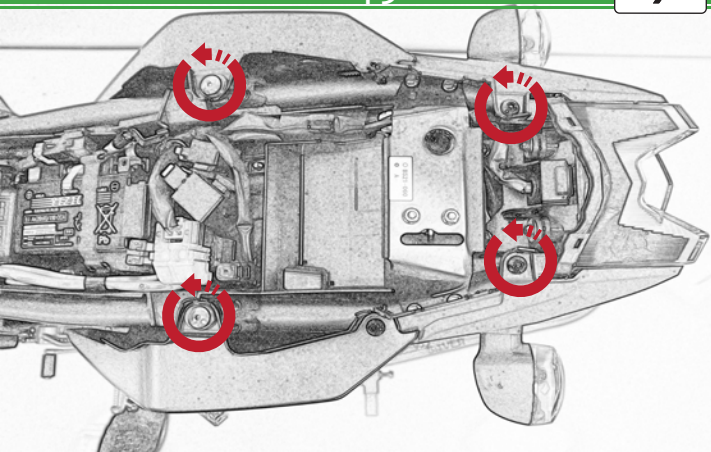

**RELEASE****RE-SET****RE-FIT**

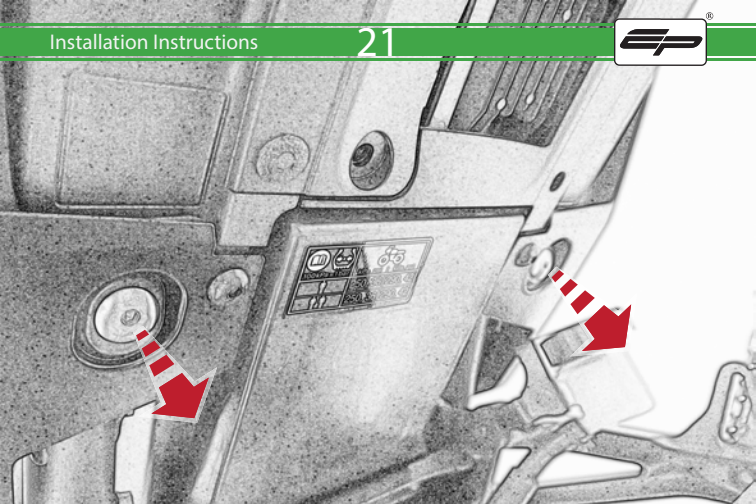

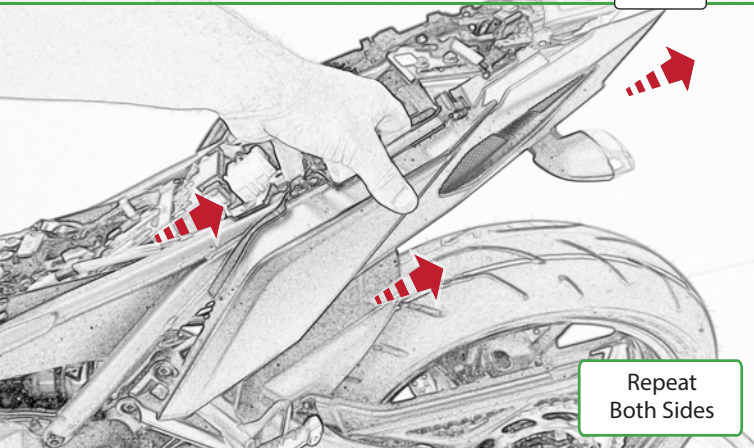

Repeat
Both Sides

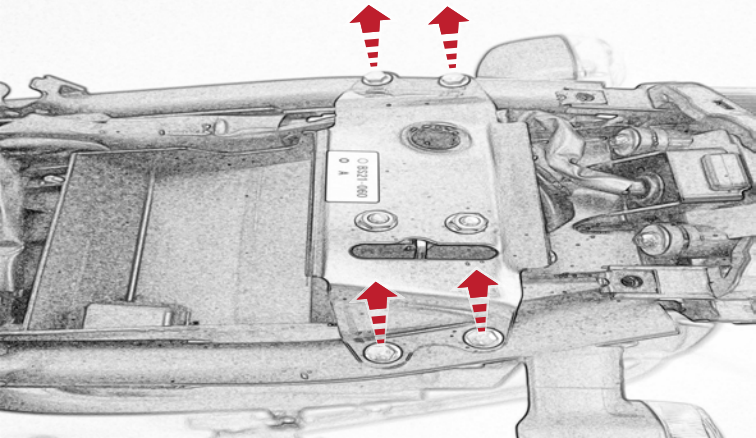

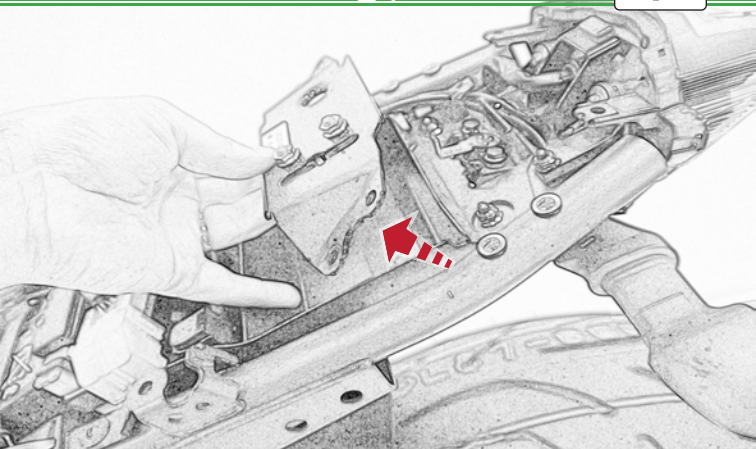

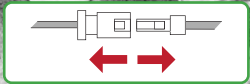
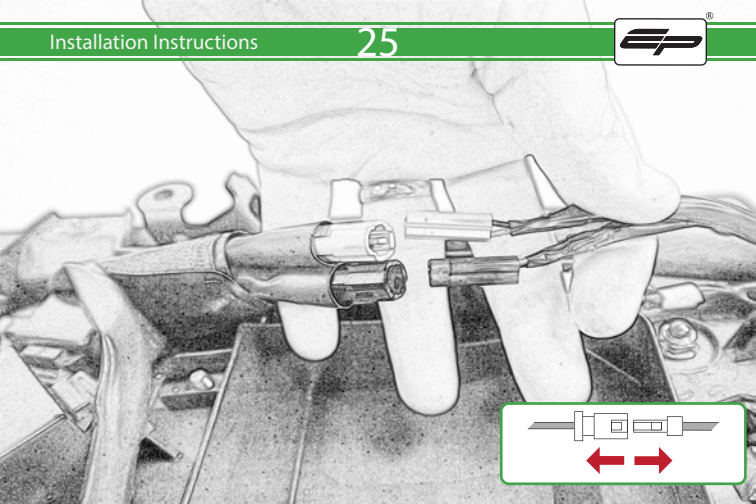

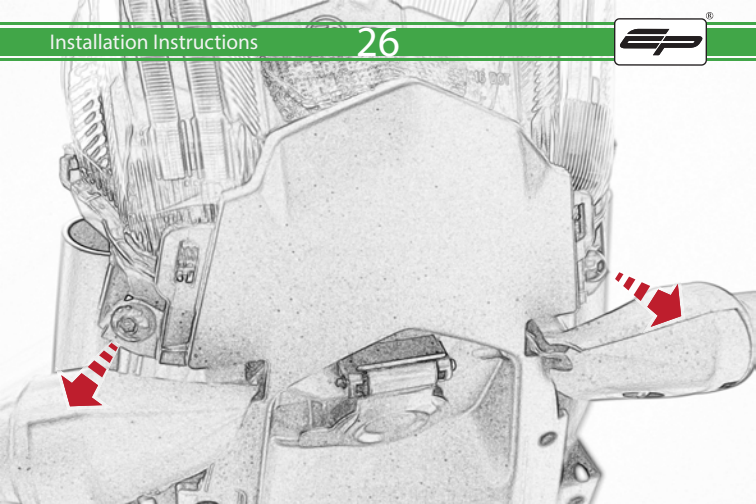

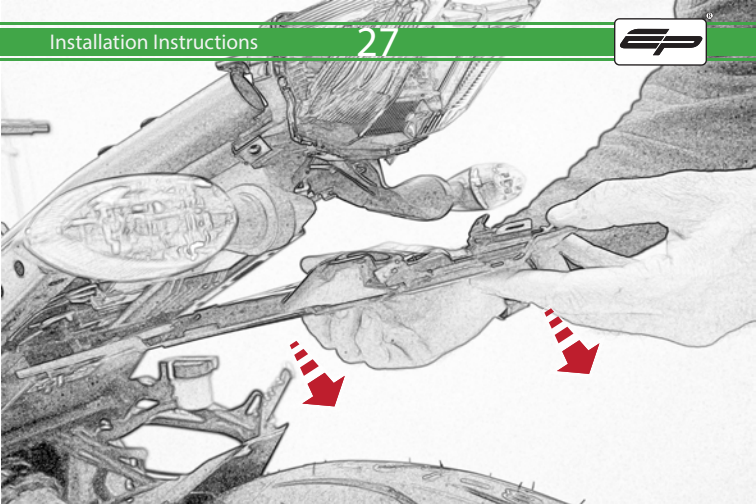

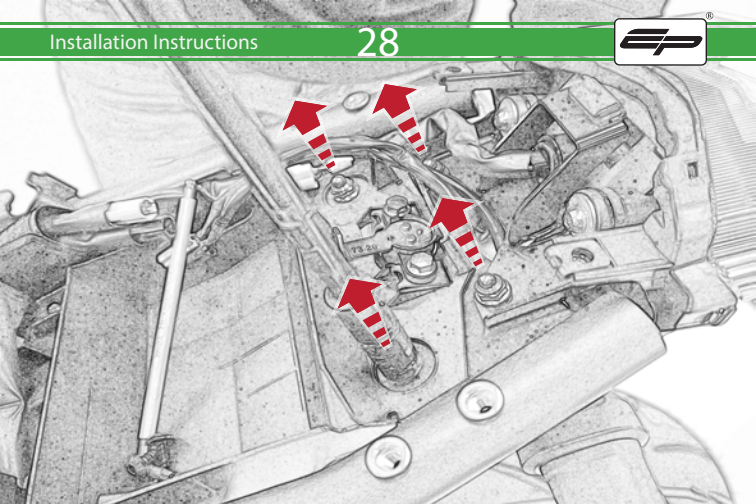

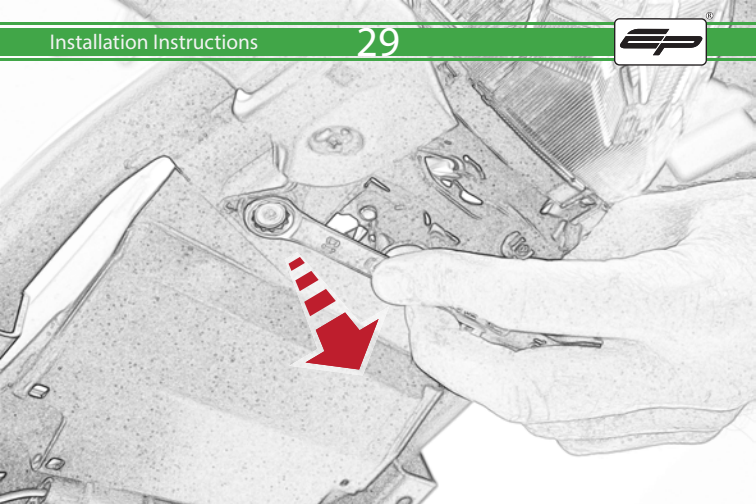

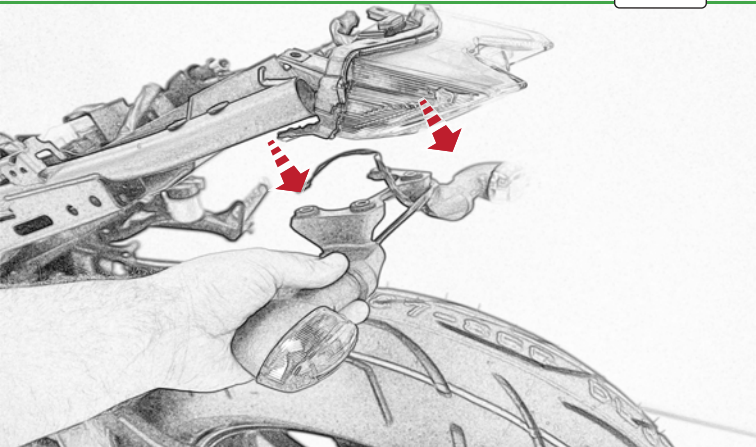

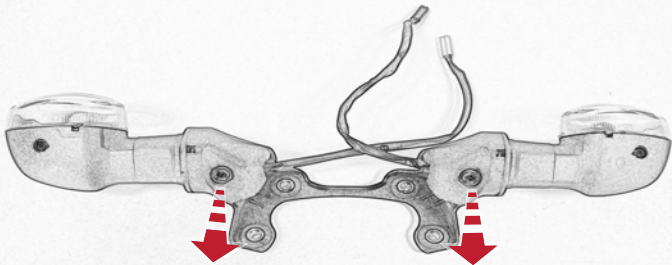

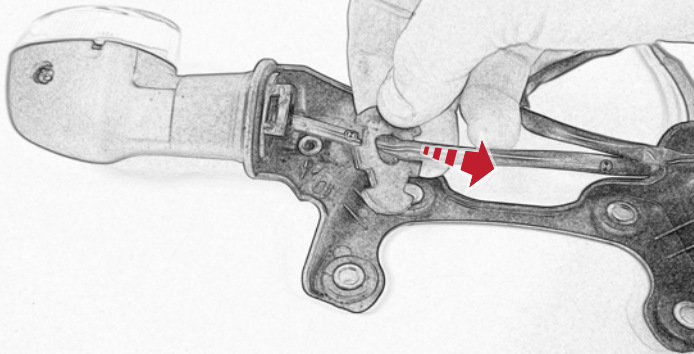

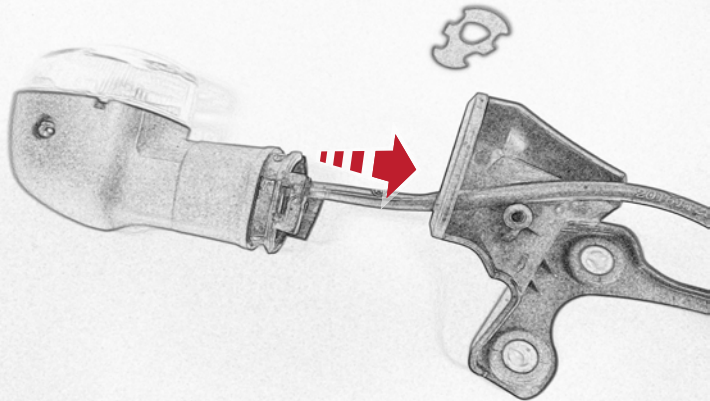

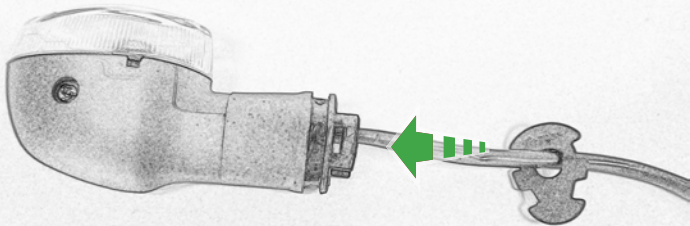

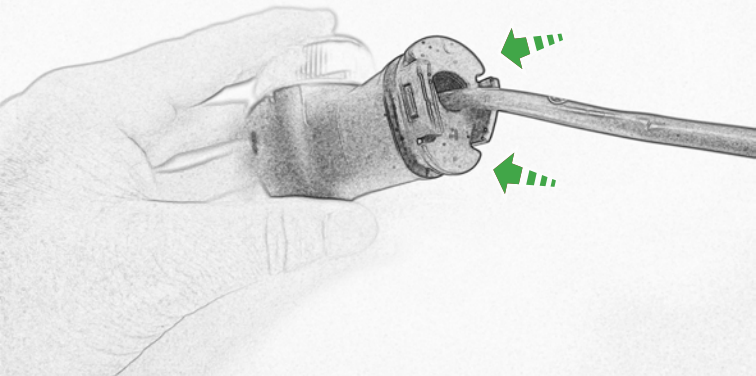

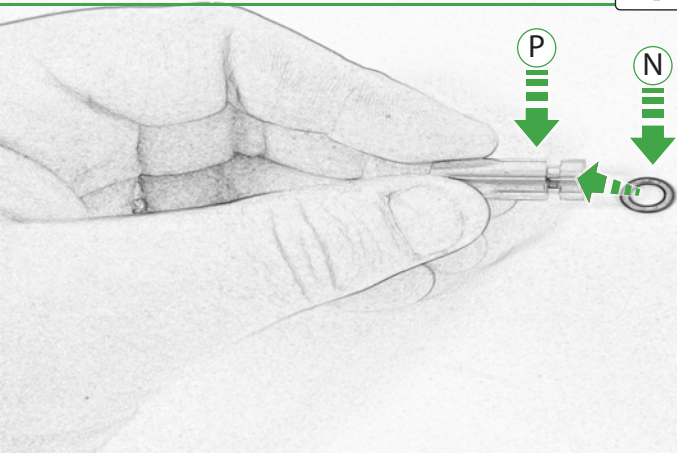

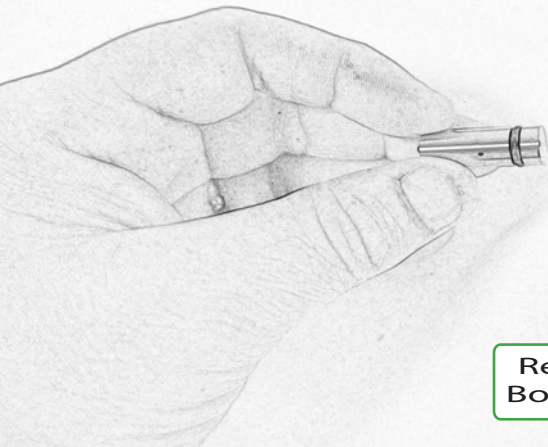

**Repeat For
Both O-rings**

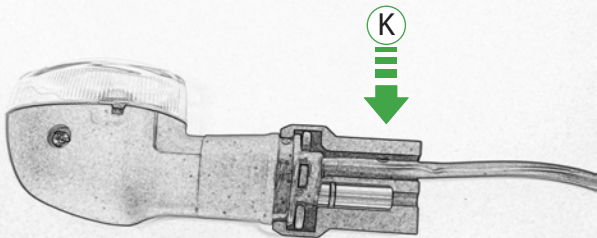

Repeat For
Both Indicators

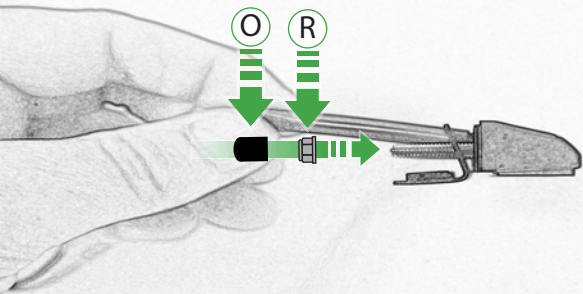

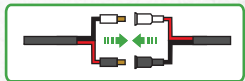
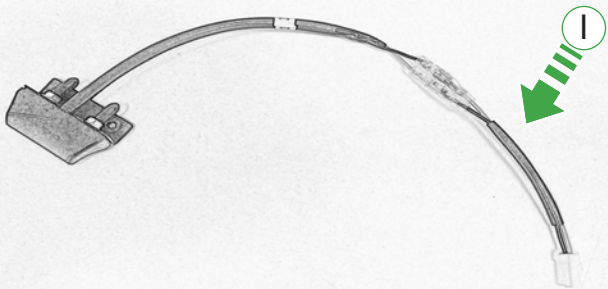

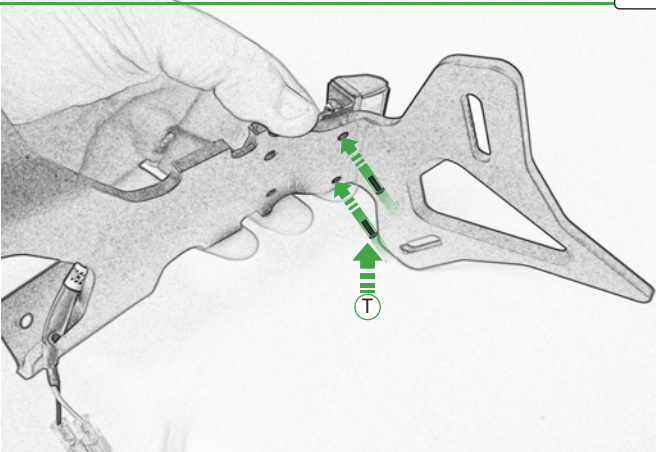

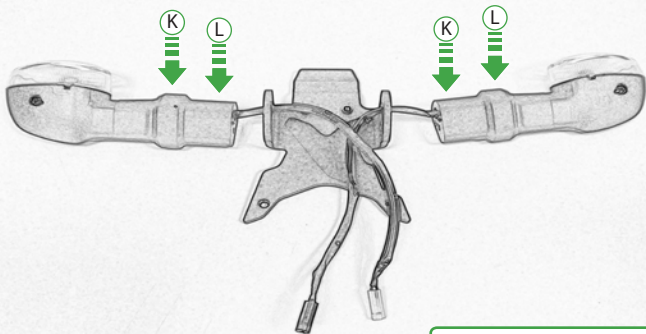

Caution

Ensure indicators are installed
on the correct sides - drain
holes should face down

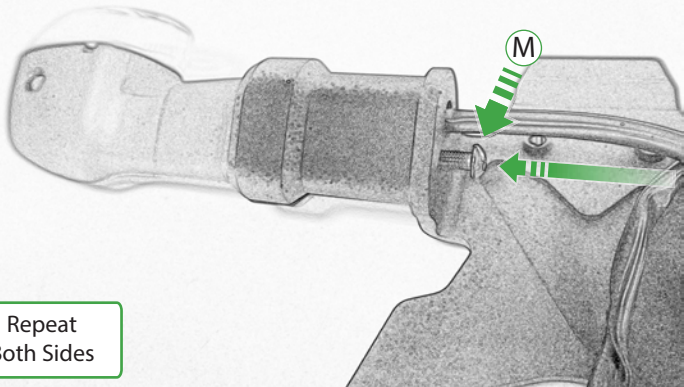

Repeat
Both Sides

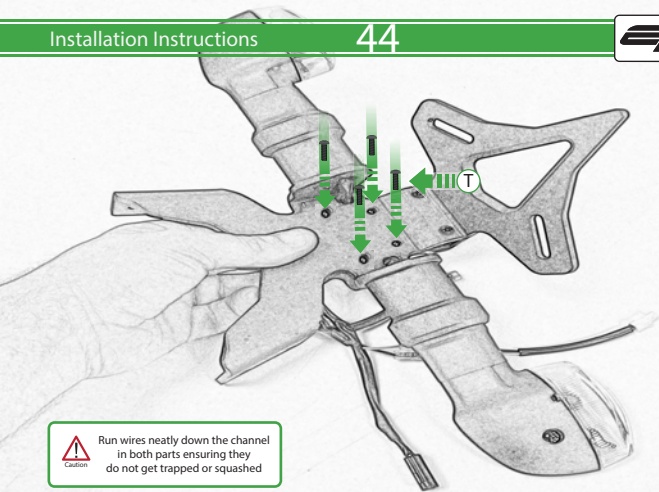

Caution

Run wires neatly down the channel
in both parts ensuring they
do not get trapped or squashed

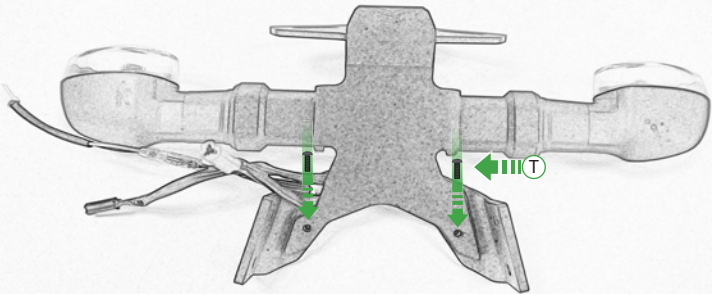

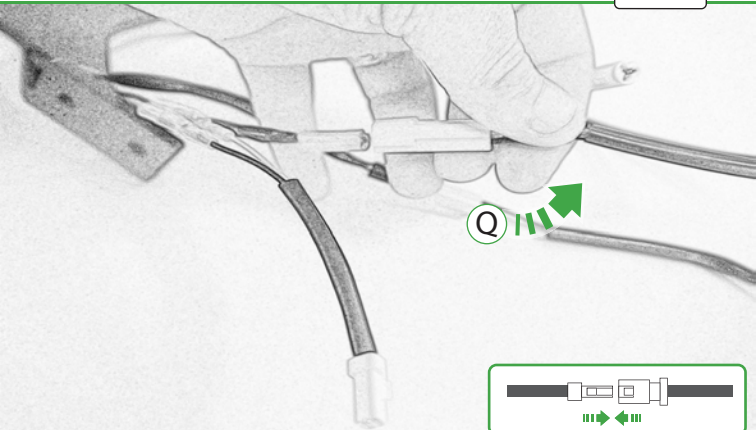

Q

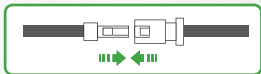

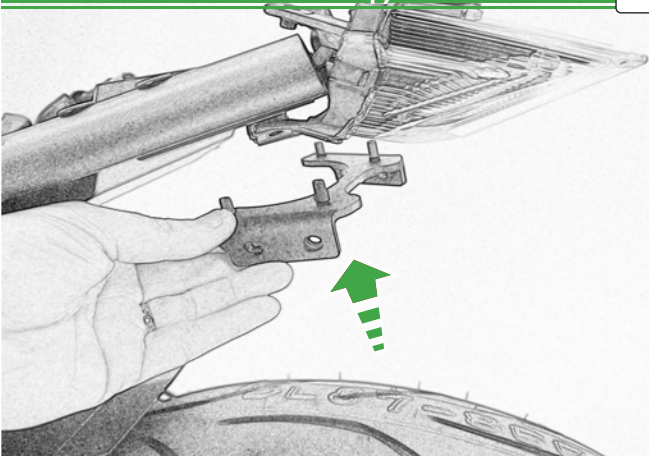

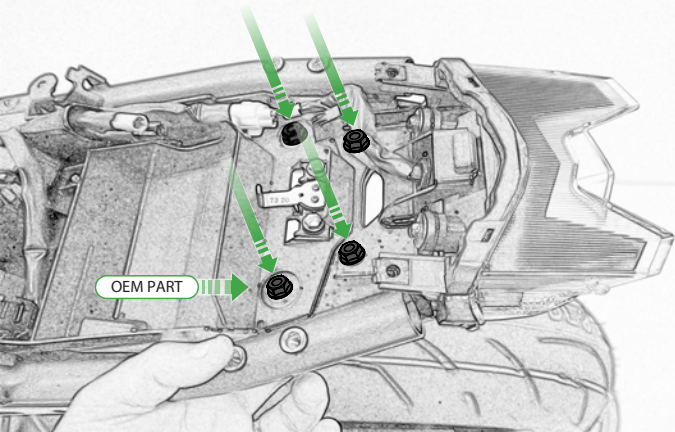

OEM PART

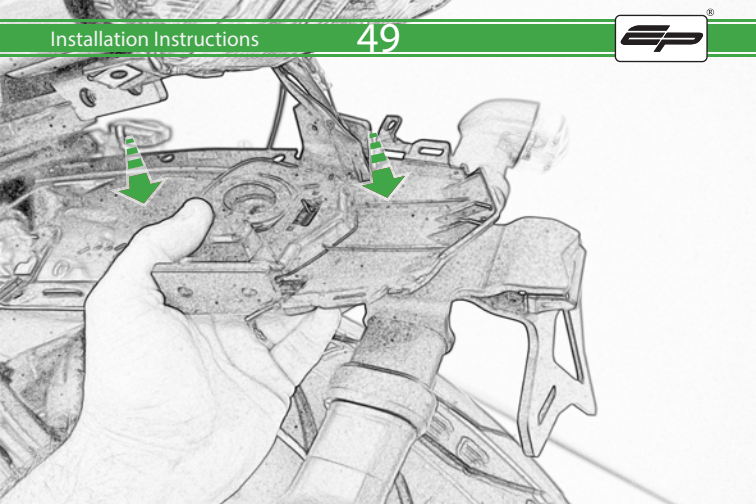

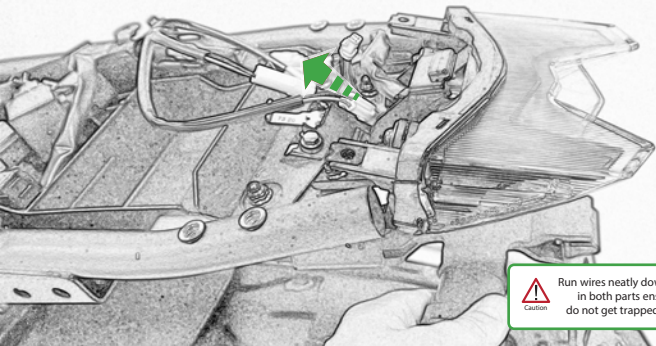

Run wires neatly down the channel in both parts ensuring they do not get trapped or squashed

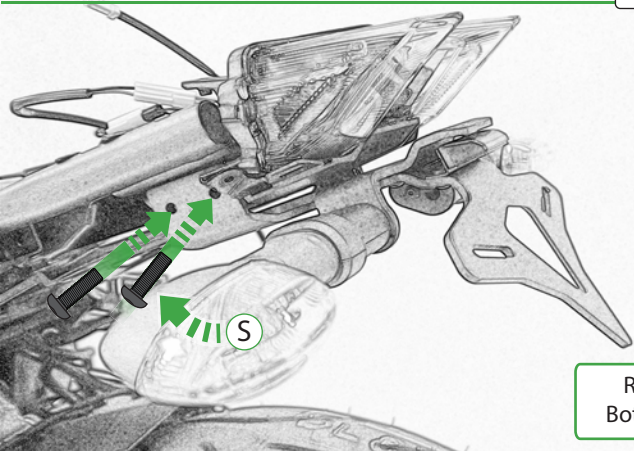

Repeat
Both Sides



OEM PART



Repeat
Both Sides

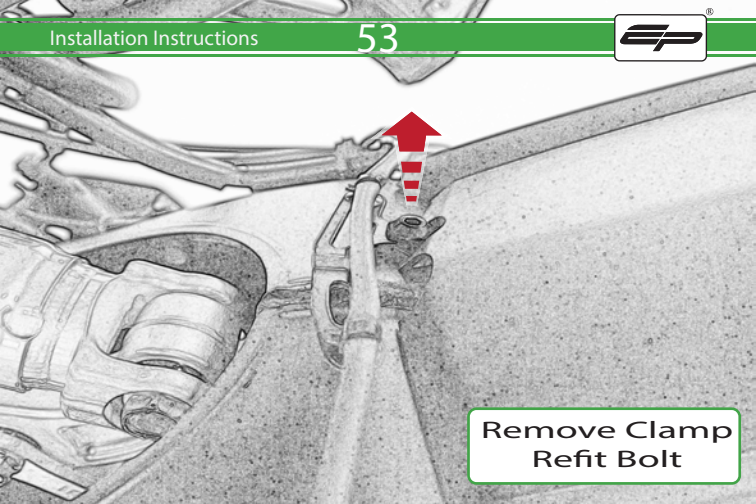

Remove Clamp
Refit Bolt

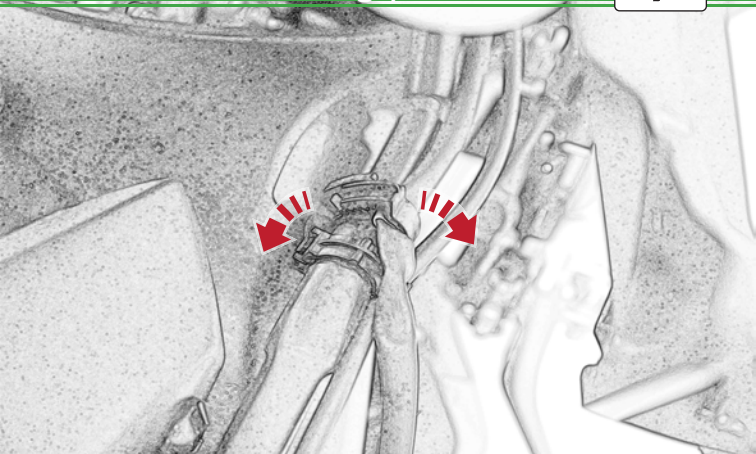

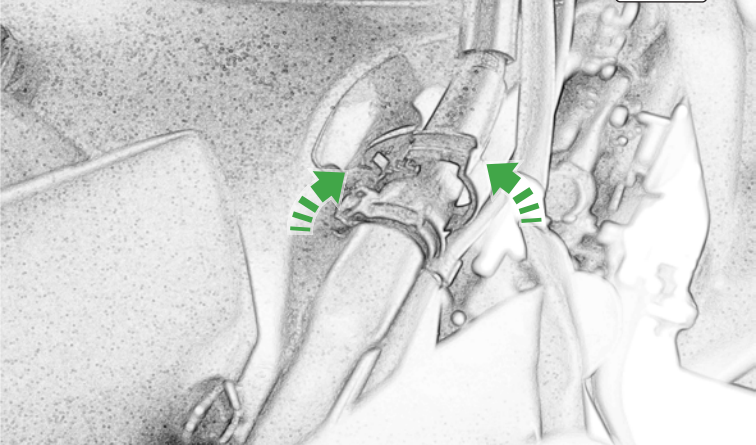

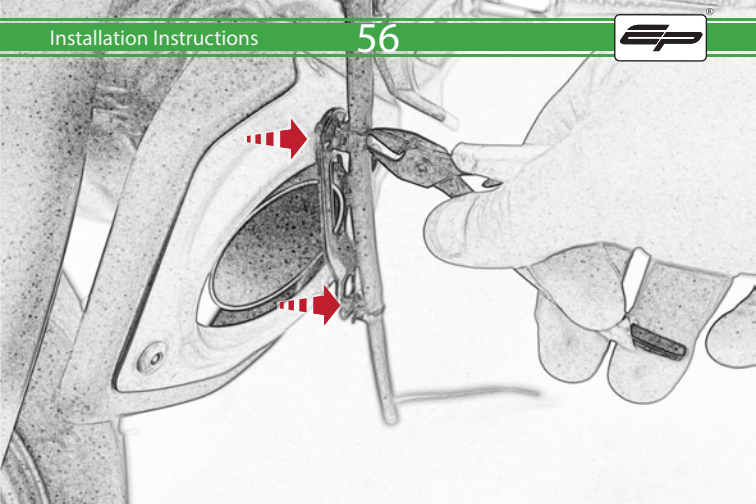

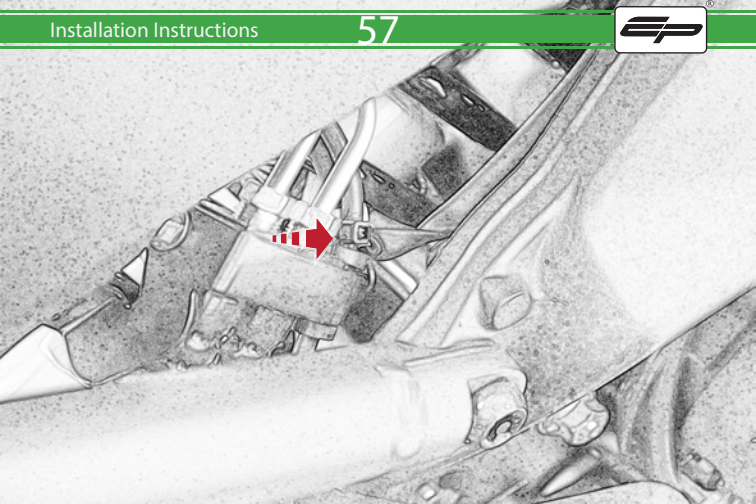

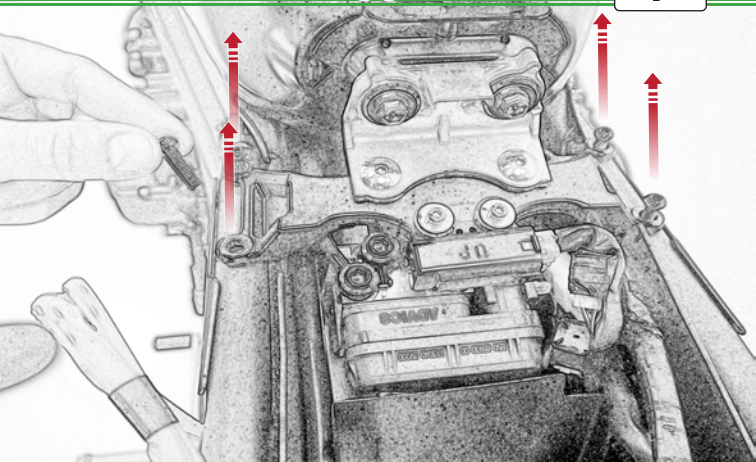

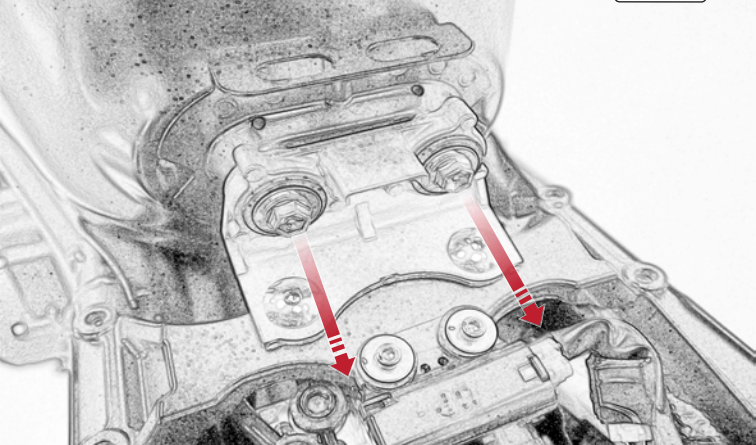

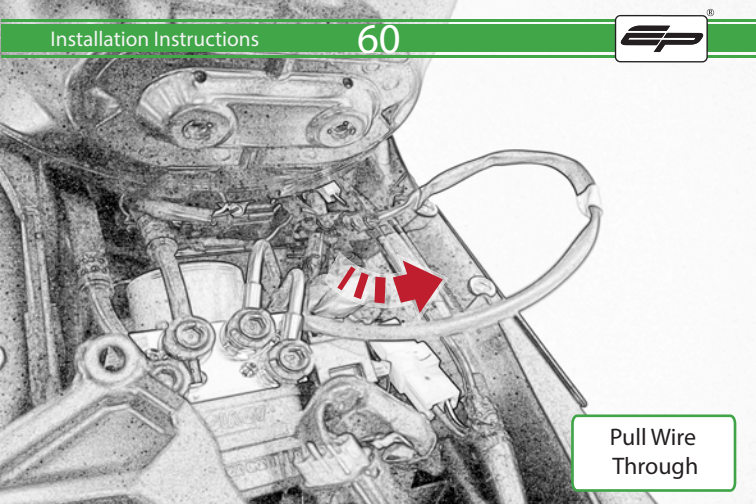

Pull Wire
Through

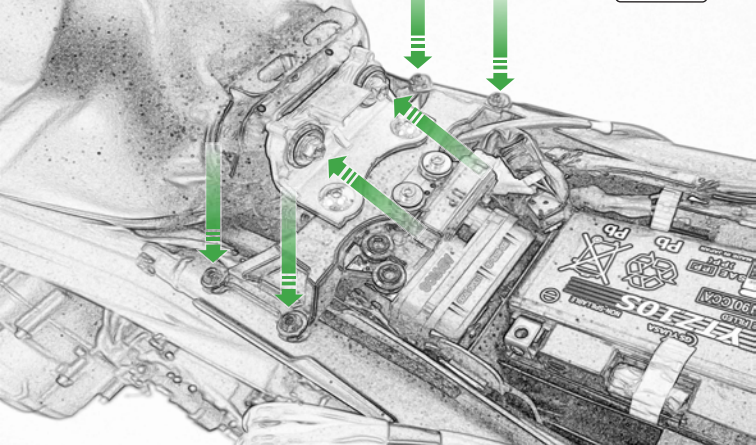

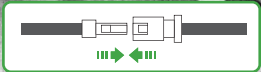
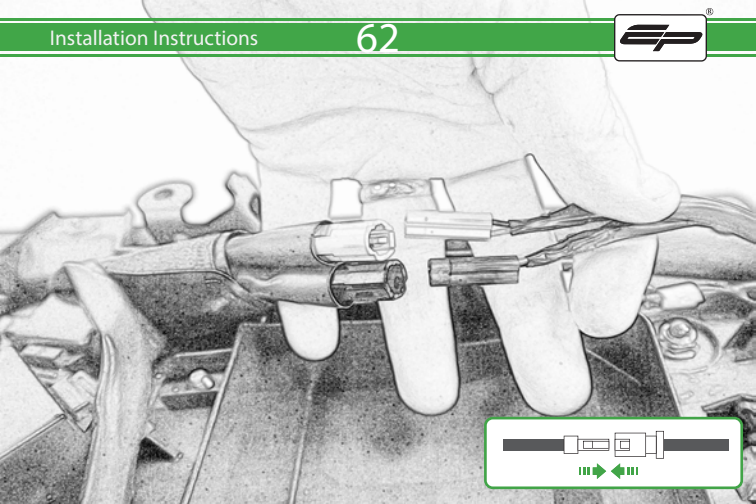



Reverse Stages

24 - 18

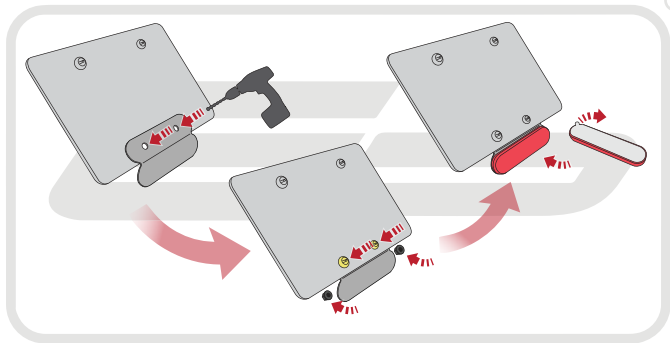

Number Plate Adaptor Installation Instructions

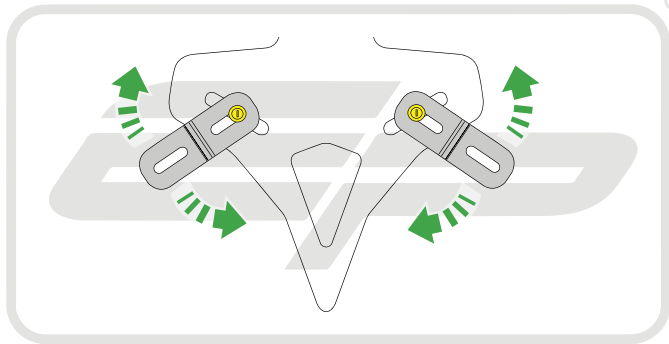

EVOTECH[®]
P E R F O R M A N C E